

How to Build the Arduino Audio Meter.

This document will guide you to build and test your Arduino Audio Meter guitar pedal. With all the materials on hand, it takes around 2-3 hours to build it. Try not to rush and take your time to do it.

We strongly recommend reviewing the entire instructions before starting. It takes 2 minutes to get a global idea of the build and may save you hours of frustration (some details like the 8x8 LED orientation is crucial, desoldering is a tedious task).

This guide aims to **build** and **test** the circuit at the same time in a logical order: placing the components from small to big and testing.

STEP 0 – Prepare the Materials.

You would need:

- Soldering iron with a small tip.
- Solder wire.
- Cutting pliers.
- Multimeter.
- Arduino Audio Meter Kit.



Keep in shorthand the important documents:

- [PCB Plan PDF.](#)
- [Schematic PDF.](#)
- [Bill of Materials PDF.](#)
- [1590BBS Arduino Audio Meter Drilling Stencil PDF.](#)

STEP 1 – Soldering Resistors:

There are 10 resistors to be placed, 6 on the top and 4 on the bottom side:

Top Side:

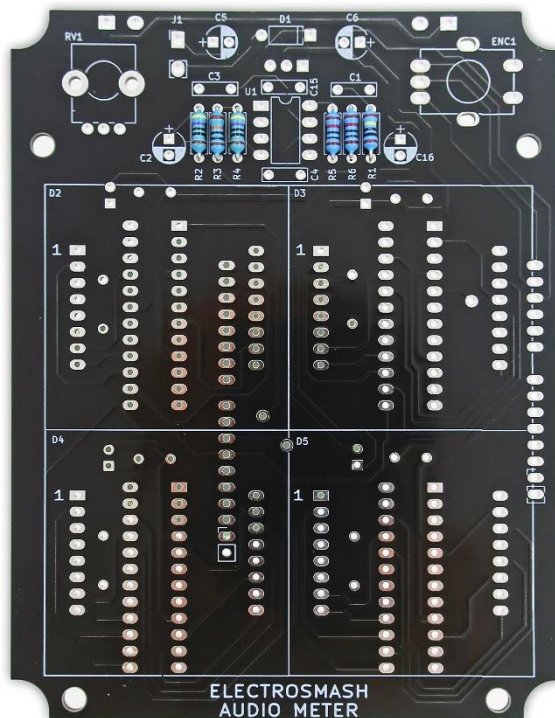
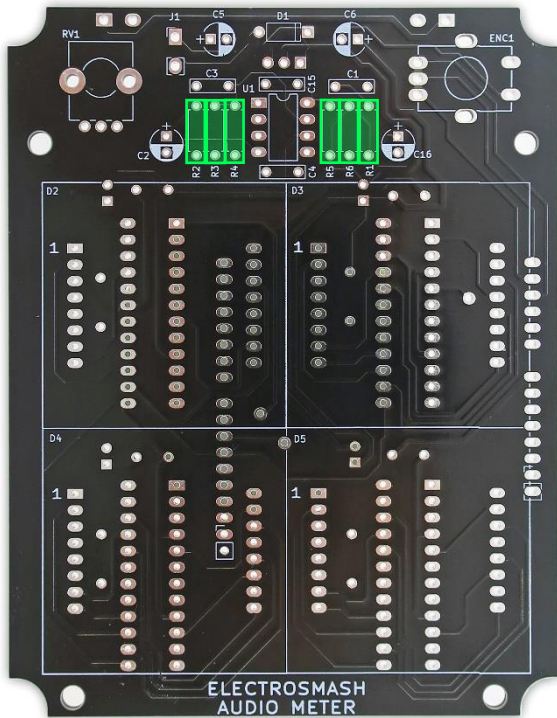

Values:

- R1 = 1M Ω
- R2 = 470 Ω
- R3 = 100K Ω
- R4 = 470 Ω
- R5 = 10K Ω
- R6 = 10K Ω

Bottom Side:

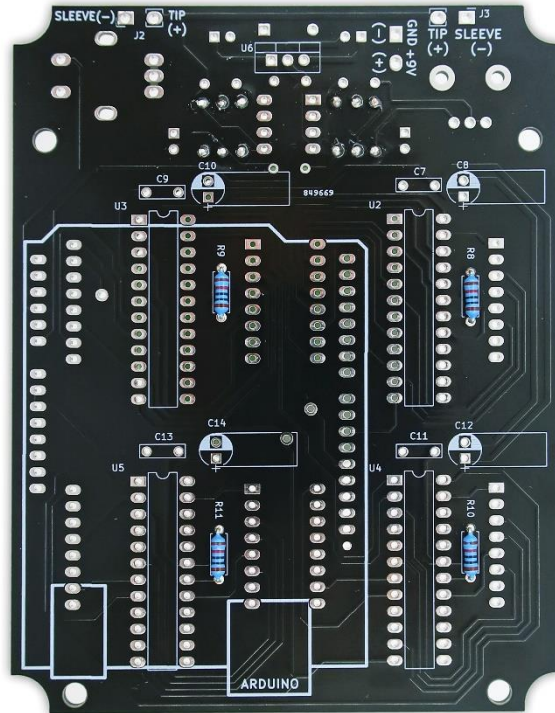
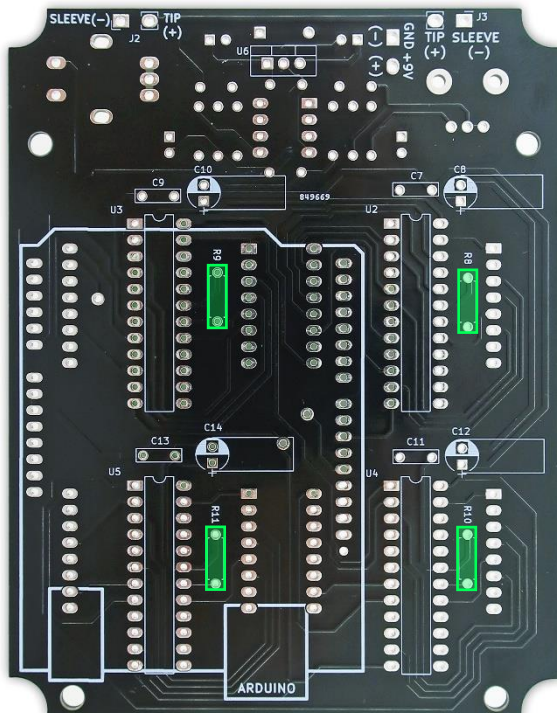

Values:

- R8 = 10K Ω
- R9 = 10K Ω
- R10 = 10K Ω
- R11 = 10K Ω

Tips before soldering:

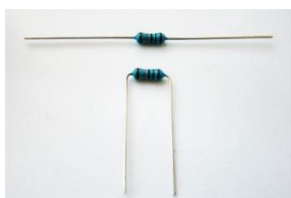

Bend the resistor leads as close to the body as possible, fit them in the footprint and once soldered cut the excess of lead as short as possible to avoid short circuits. Once the legs are cut, touch again with the soldering iron the joint to secure the connection.

STEP 2 – Soldering the Caps:

There are 16 capacitors to be placed, 8 ceramics and 8 electrolytics:

Top Side:

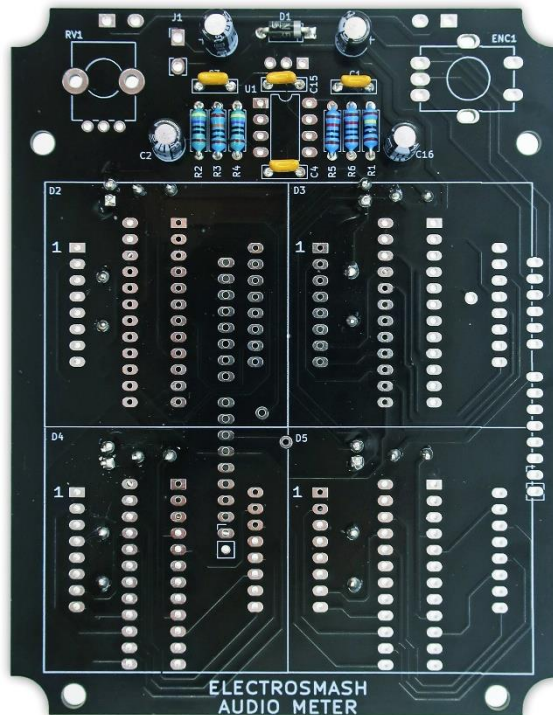
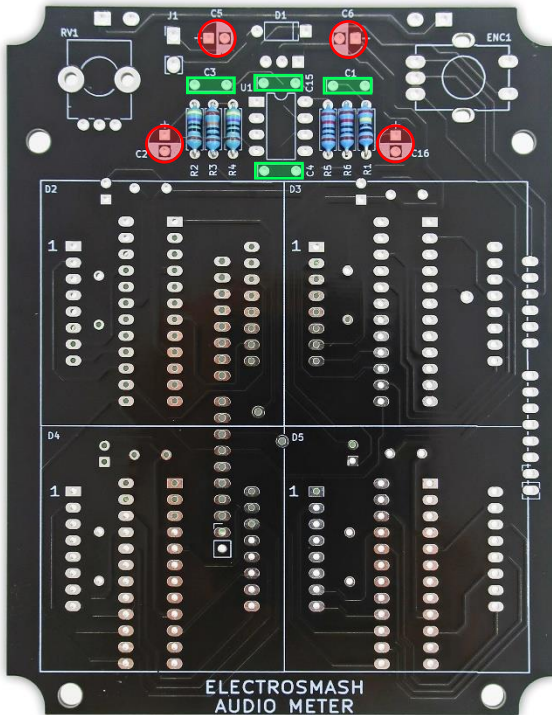

Values:

C2 = 10uF
C5 = 10uF
C6 = 10uF
C16 = 10uF

C1 = 100nF
C3 = 270pF
C4 = 270pF
C15 = 100nF

Bottom Side:

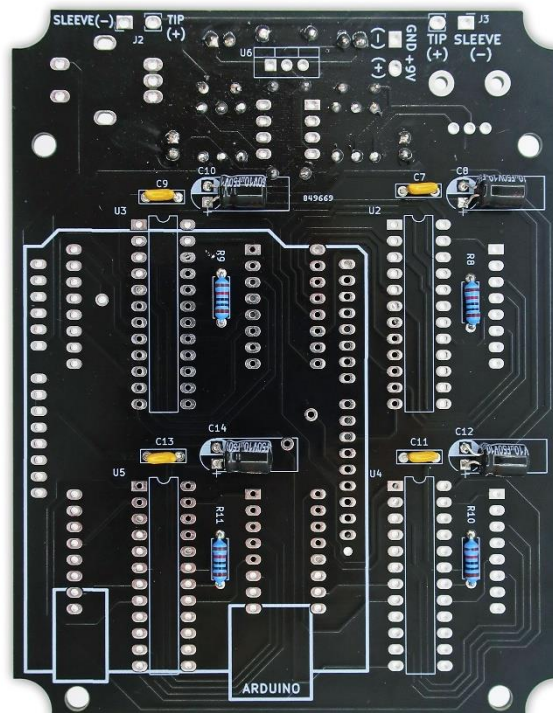
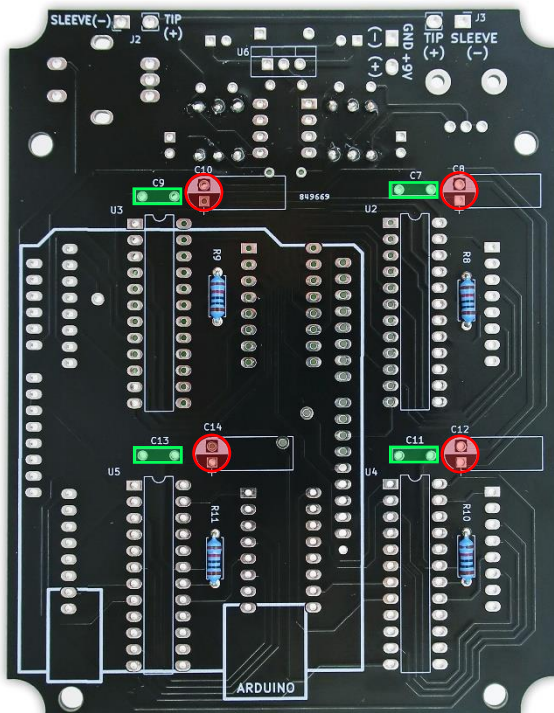

Values:

C7 = 100nF
C9 = 100nF
C11 = 100nF
C13 = 100nF

C8 = 10uF
C10 = 10uF
C12 = 10uF
C14 = 10uF

Note: The electrolytic caps have polarity, insert the long lead into the hole labelled with "+"



You would need to bend the legs of the C8, C10, C12, C14 caps in a 90° angle so they won't crash with any other parts inside the enclosure.

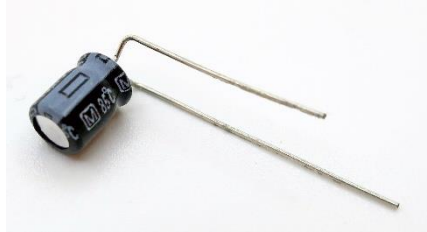

STEP 3 – Soldering Big Components:

There are 18 electrolytic capacitors to be placed.

Top Side:

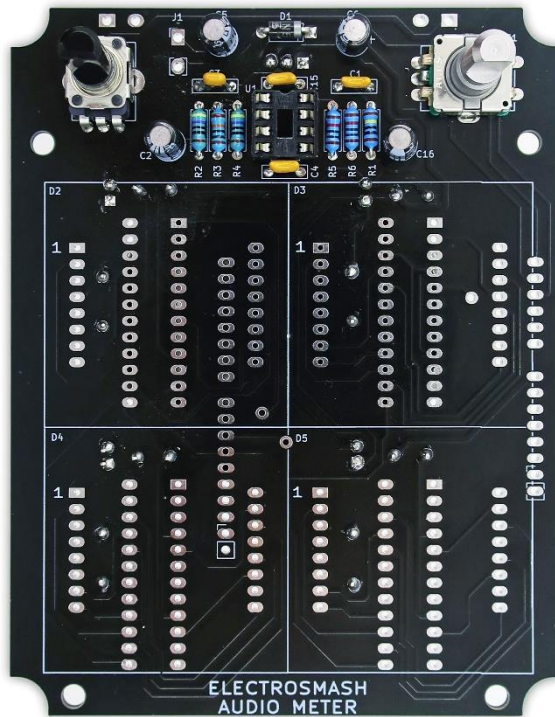
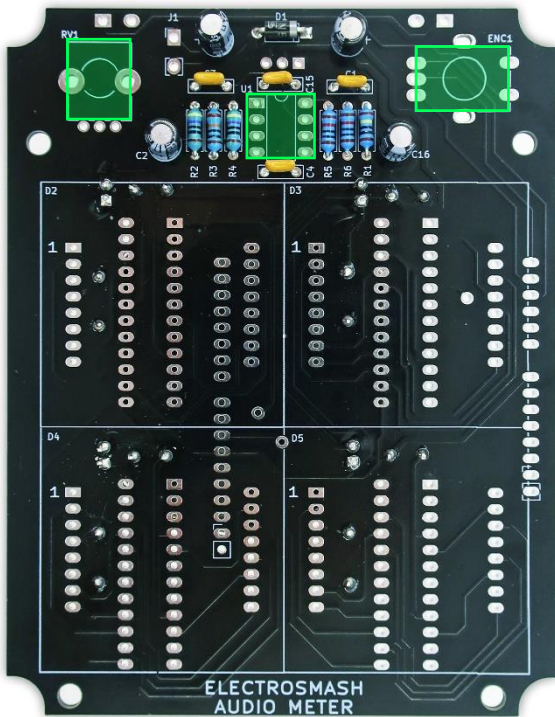

Values:

U1 = socket + MCP6002

RV1= 100K potentiometer.

ENC1 = Encoder with push-button

Bottom Side:

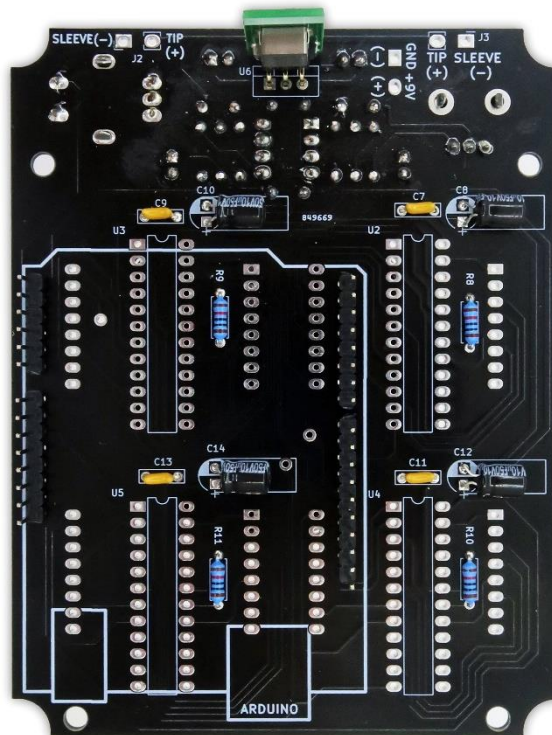
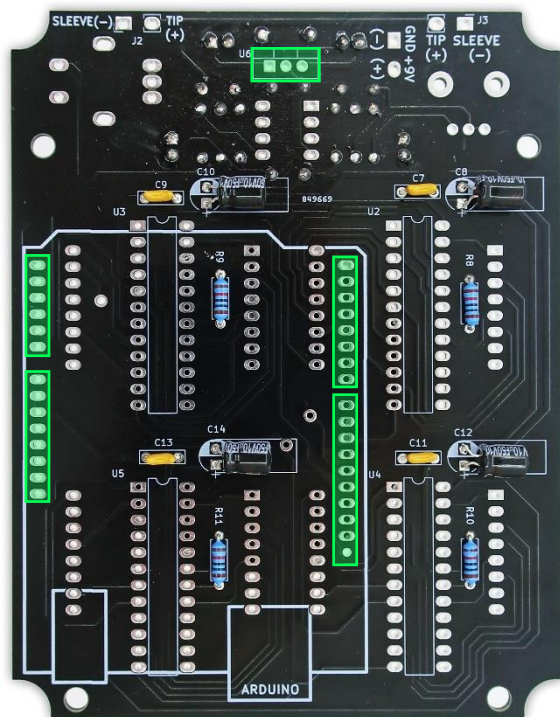

Values:

U6 = VXO7805-1000

Pin Headers x 4

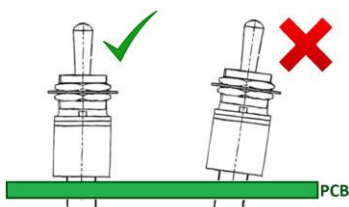

Note: Big components tend to tilt when soldered. Make sure they are straight: A good idea is to solder only one pin and once you are sure that it is perpendicular, solder the rest of the pins.

Make sure that the 9V to 5V regulator (U6) is soldered with some space between the PCB and the part, so short circuits are avoided:

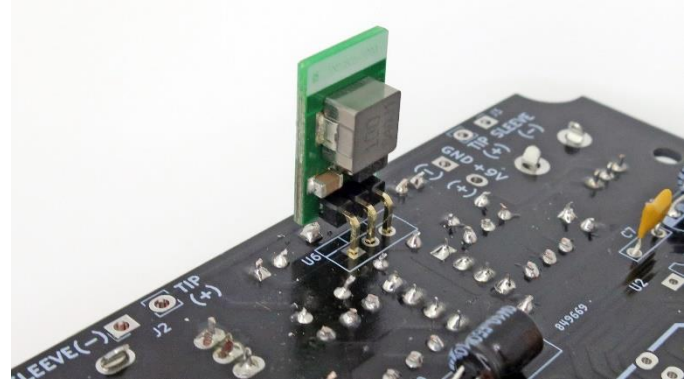
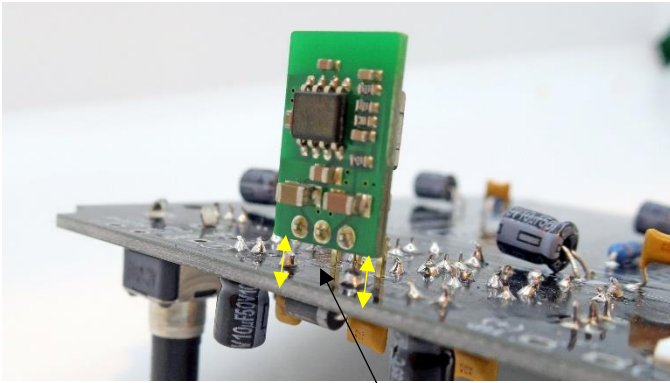

Clearance between the board and the chip

Note: The 40 pins strip needs to be cut into smaller pieces (10, 8, 8, and 6 pins).

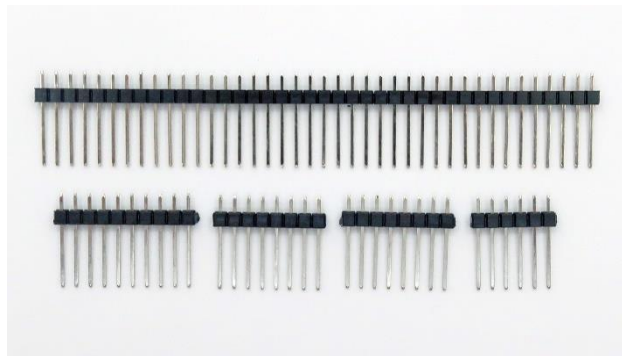

STEP 4 – Solder one LED matrix and test it:

We are going to solder one MAX7219, one 8x8 Matrix and check that all is working fine:

Bottom Side – **IMPORTANT:** solder first the MAX7219 (bottom) and then the 8x8 LED matrix (top). Otherwise you won't be able to access the pins.

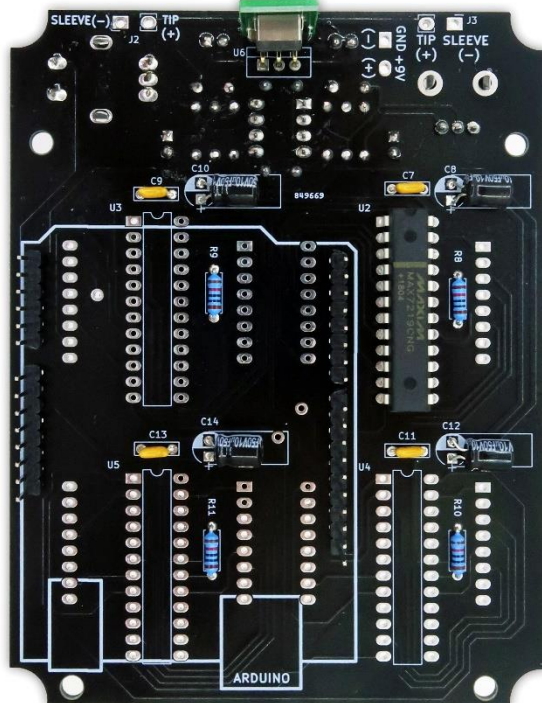
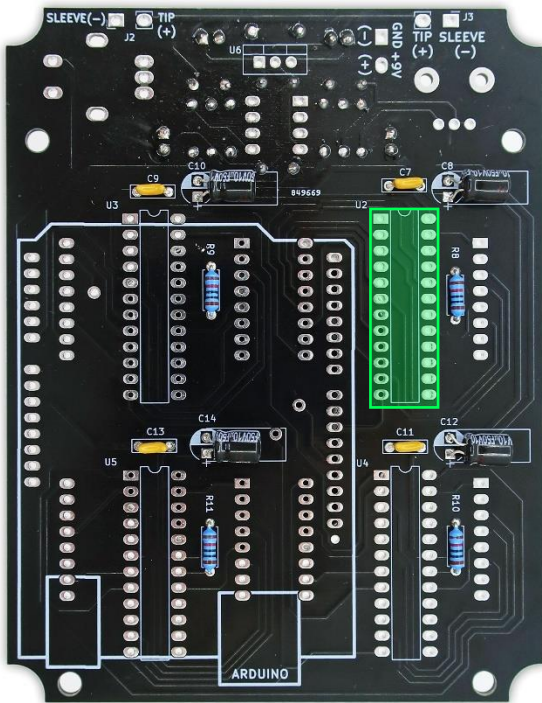

Values:
U2 = MAX7219

Top Side:

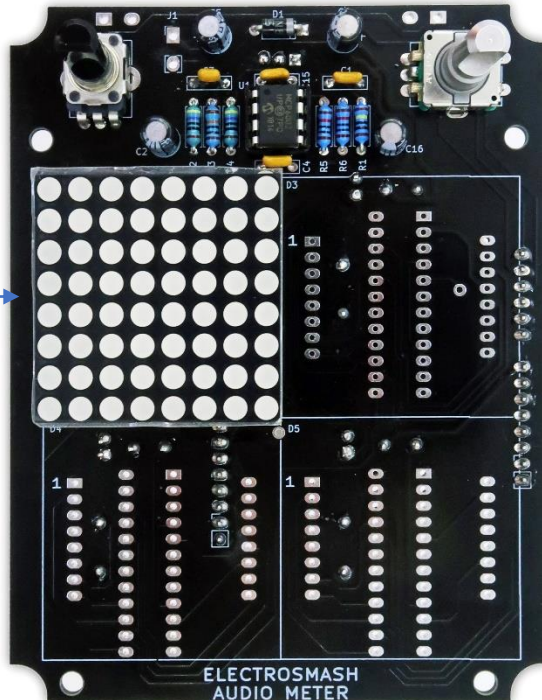
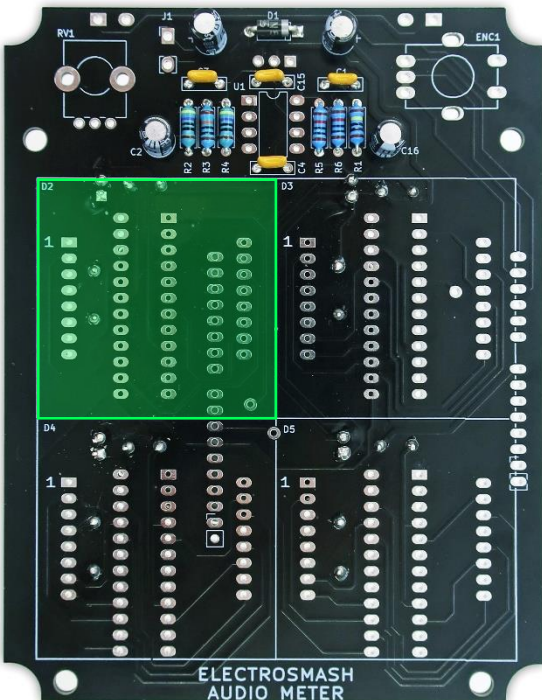

Values:
D2=8x8LED matrix

Important: the 1588BBS writing goes in this side of the 8x8 LED matrix, don't place it reversed

Testing:

After installing one 8x8LED matrix, you can use the [Test one 8x8LED.ino program from the forum](#) to check that all is working fine:

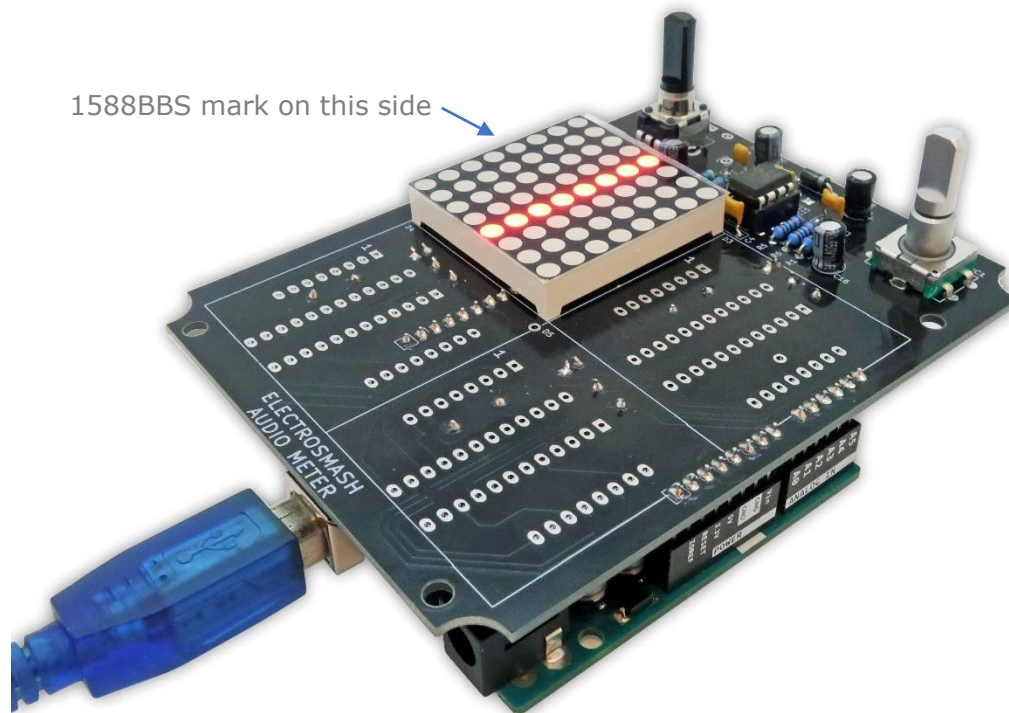

The code will light up one column of LEDs and move it from left to right.

Note: You do not need external power supply for this, you can use the USB cable to power the system.

STEP 5 – Soldering the rest of the 8x8 LEDs and drivers

After testing that one 8x8 matrix is working fine, it is time to solder the rest of the matrices. Make sure that you solder first the bottom side and then the top side:

Bottom Side:

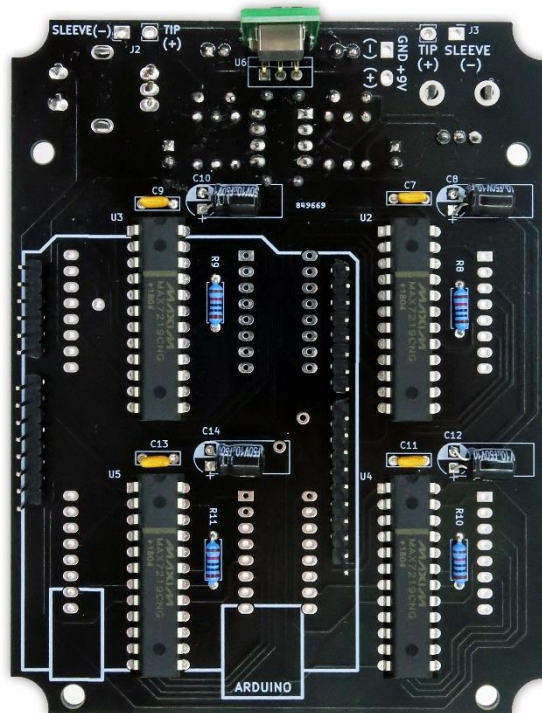
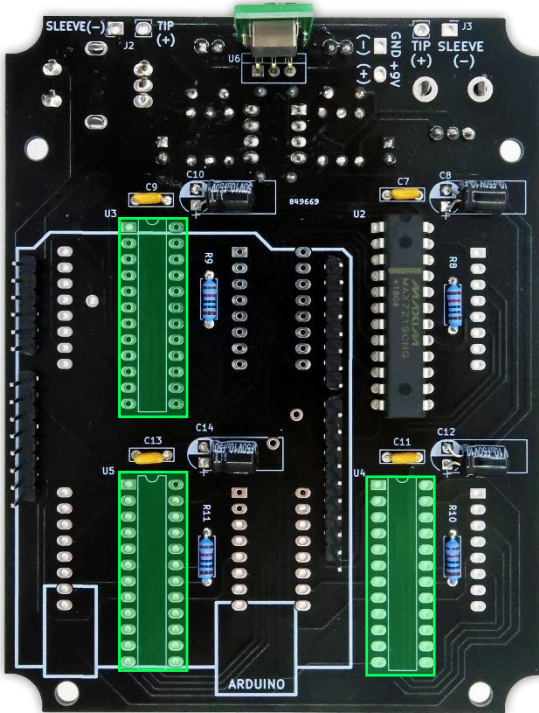

Values:
U3, U4, U5 =
MAX7219

Bottom Side:

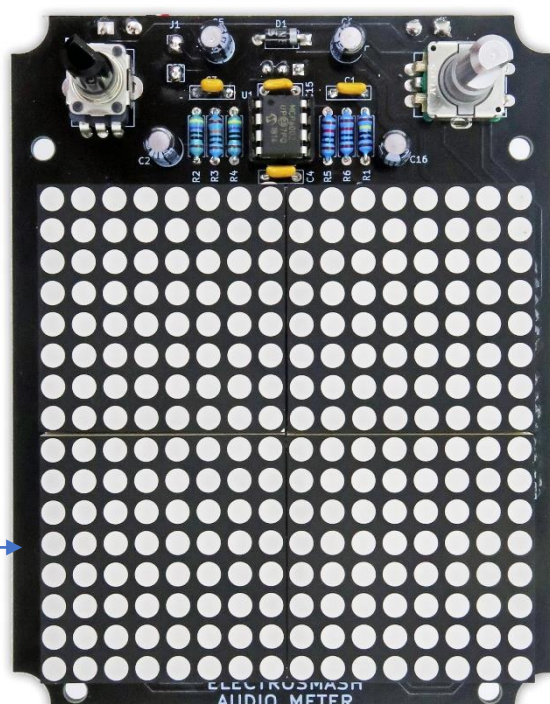
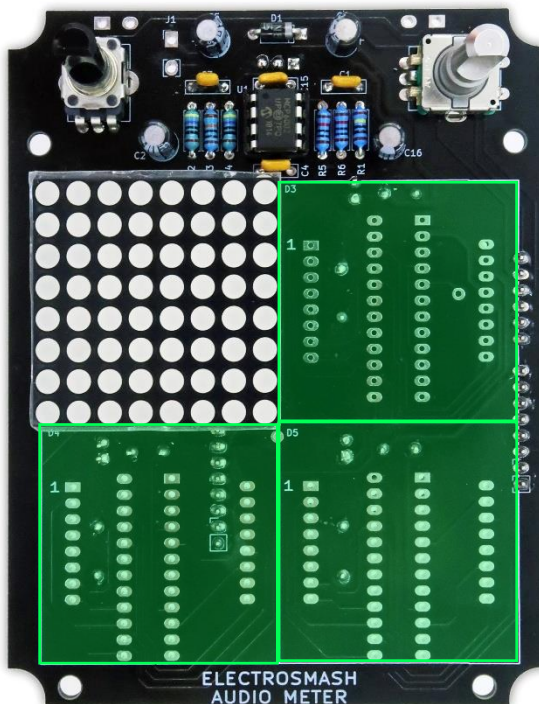

Values:
D3, D4, D5 =
8x8LED matrix

Important: the 1588BBS writing goes in this side of the 8x8 LED matrix, don't place it reversed

STEP 6 – Solder the wired components:

The last step is to solder the input/output jacks and the 9V-12V DC jack using 6 short wires:

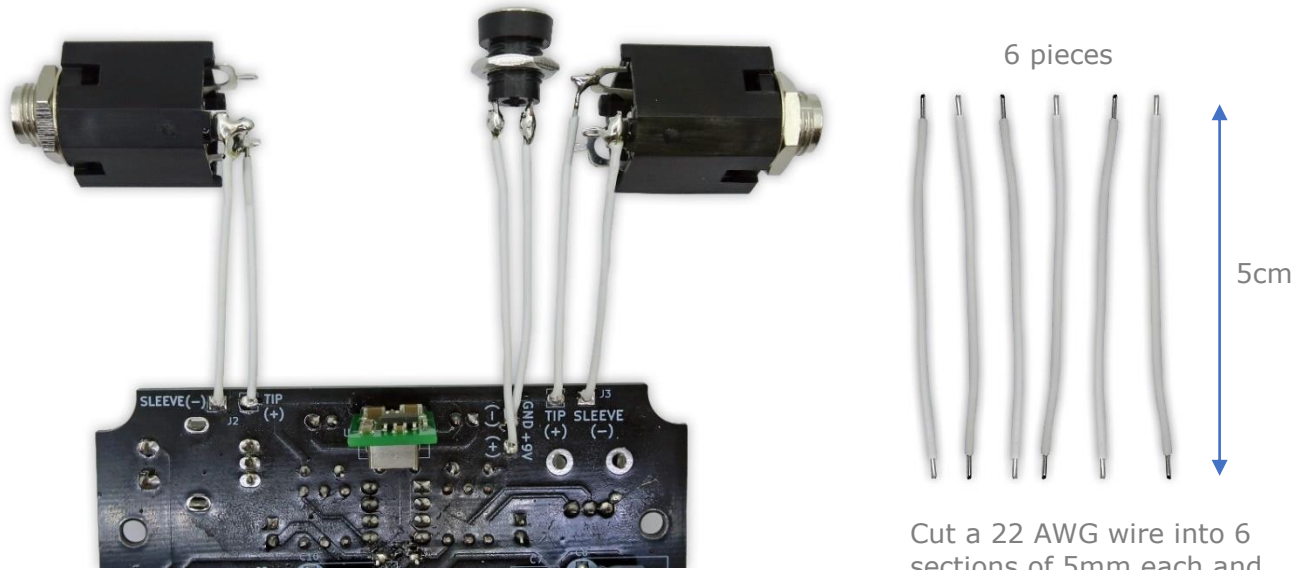

Soldering the ¼" Audio Jacks:

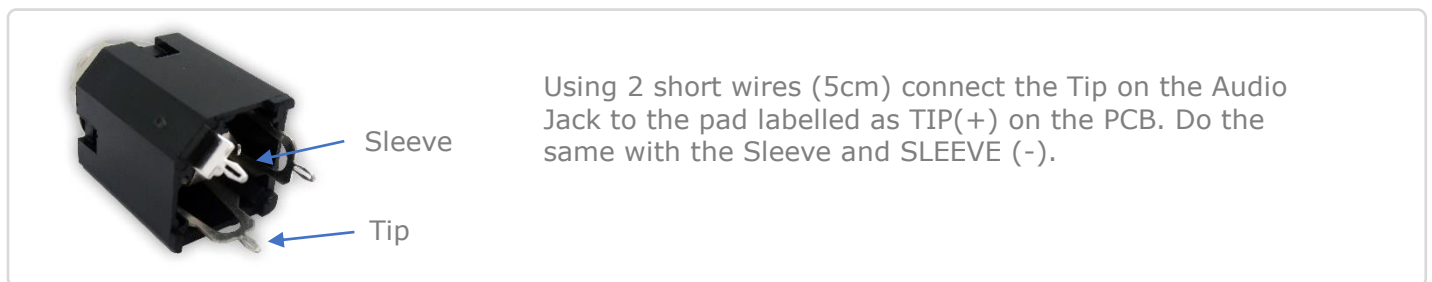

Soldering the 2.1mm DC Jack:

You can use any power supply from 9V to 12V, but they should give at least 600mA of output current. There are 2 options, depending if you are using a centre positive or negative power supply adapter:

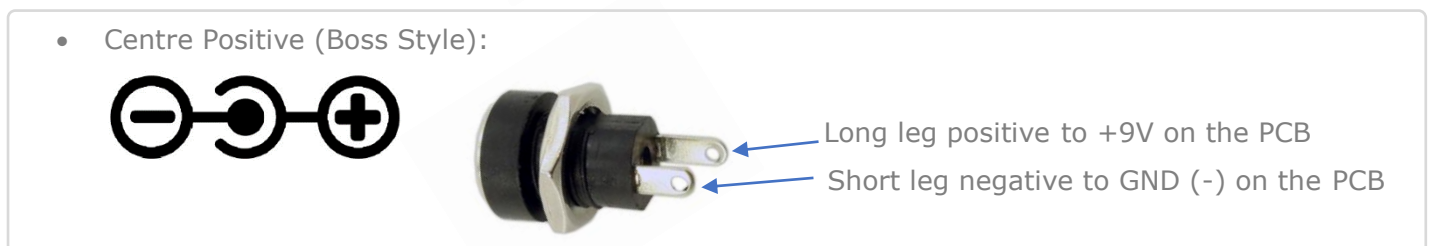
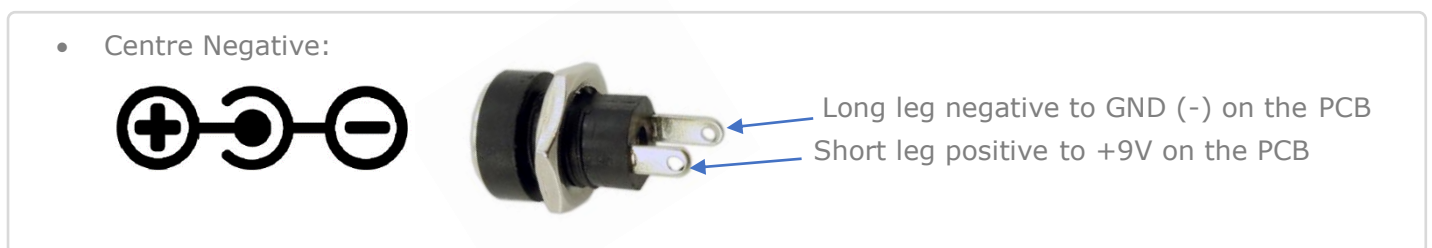

Note: You would need to desolder and solder again the power jack once you put together into the enclosure.

STEP 7 – Checking the Board Voltages:

Before loading codes and started programming, it's important to check the voltages.

- Use a multimeter with the negative (black) lead connected to 0V on the image.
- Connect the DC adapter, but not input/output jacks.

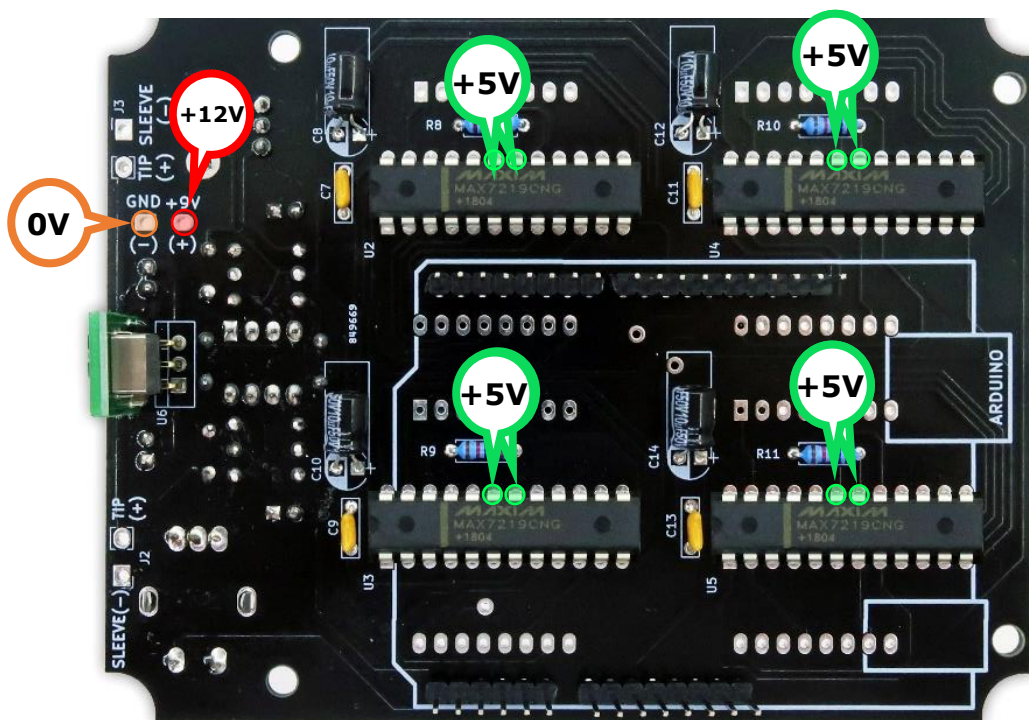
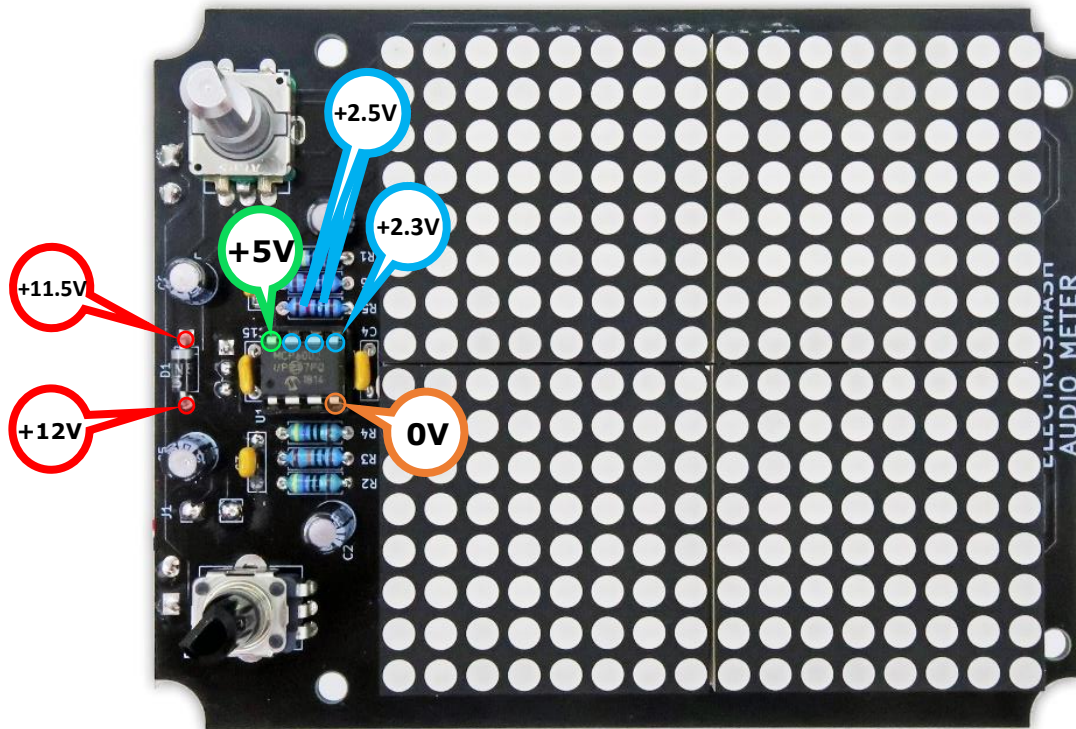

Note: The voltages above are measured using a +12V input supply, if you are using a +9V supply (common in guitar pedals) just replace the +12V by +9V and +11.5V by 8.5V.

STEP 8 – Final Test.

At this point, you are ready to use the pedal. It is designed to be checked before being boxed, so makes everything easier to fix and mod.

[Load the Test All 8x8LEDs.ino code from the forum.](#)

Once loaded, disconnect the USB cable and power it using the external supply.



Note:

- In this pedal, the input and output are interchangeable, so you can connect the guitar and the amp in either sides of the pedal:



STEP 8 - Mount the Pedal into the Enclosure:

The last step is to put all together into the Hammond 1590BBS box:

- 1- First, attach the acrylic cover to the PCB using the 8 screws and the 4 nylon spacers.

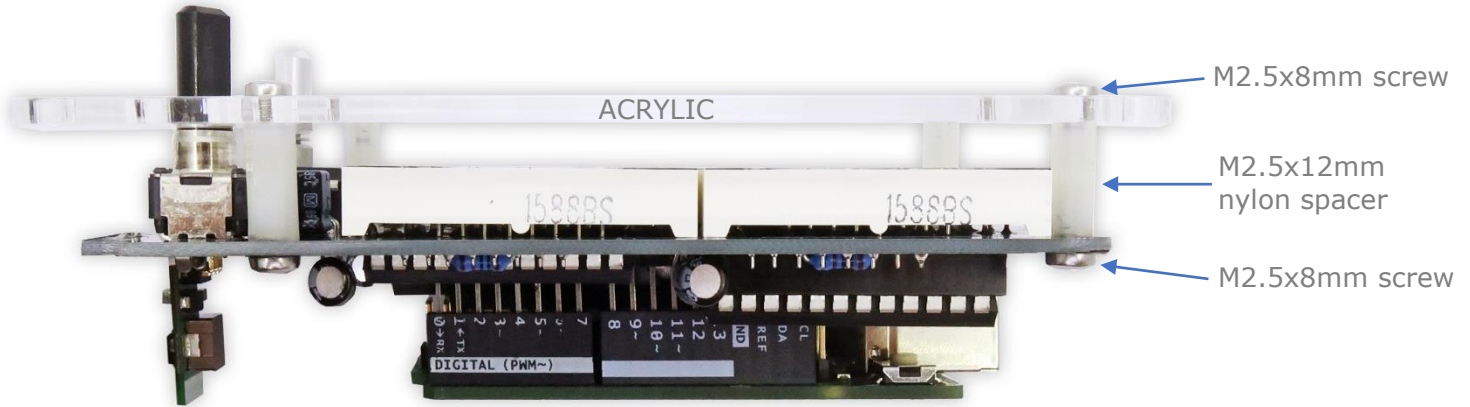

Note: Do not overtighten the screws that touch the acrylic. Make sure that they go firm but be gentle not to break the acrylic cover.

- 2- Plug the Arduino UNO Board.
- 3- Fix the audio jacks and DC jack connector to the enclosure with nuts.

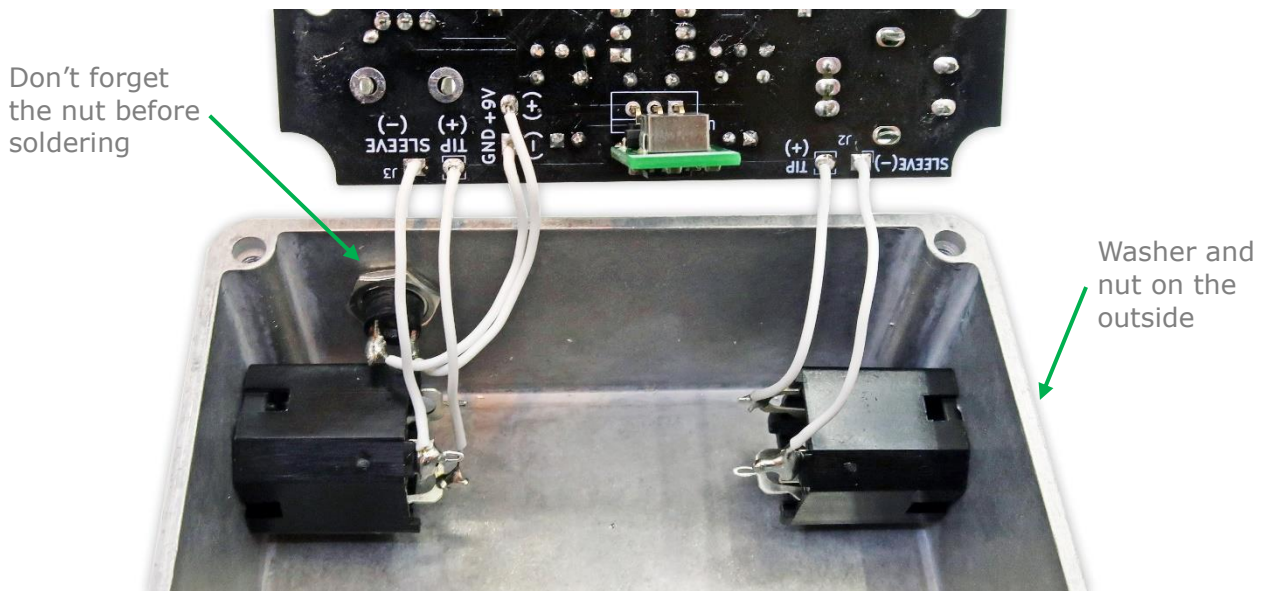

- You may need to unsolder/solder again the DC jack (make sure that the polarity is right).
- Make sure that all the soldered parts have their legs cut as close as possible to the PCB

- 4- Finally put the board into the Box, make sure that all goes tight but there are no short circuits and the regulator is not touching the metal enclosure.

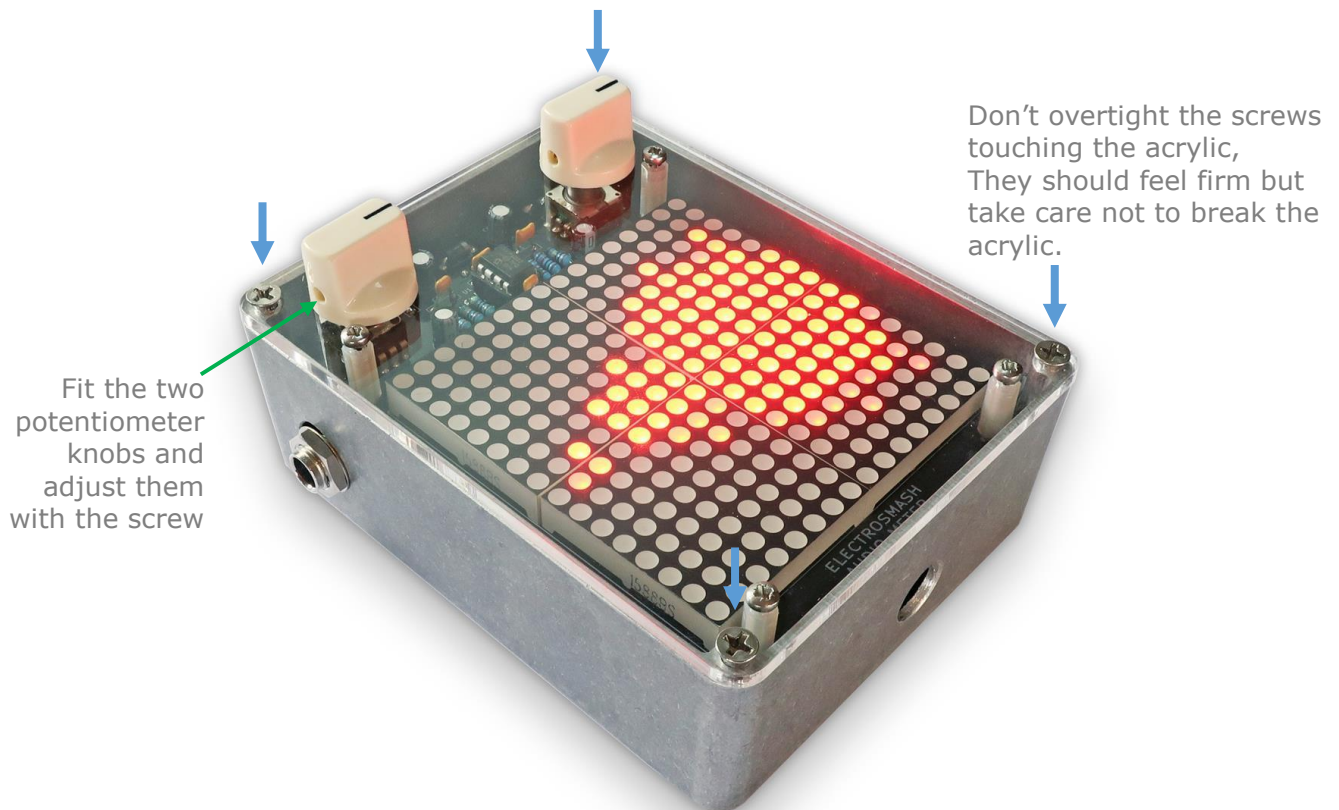

Once the build is finished, you can go to the ["How to Start Programming the Arduino Audio Meter"](#) in the forum.

Appendix: Enclosure Drilling Stencil.

The project is designed to fit in a Hammond 1590BBS enclosure, there are more models in different colors with a different reference number (1590BBSYL, 1590BBSRD, 1590BBSPR, 1590BBSOR, 1590BBSLG, 1590BBSGR, 1590BBSCB, 1590BBSBK)

This is the Hammond 1590BBS drill stencil, you can also [download the PDF](#) file.

